

Applications

- Engines
- Motors
- Pumps
- Air Conditioner
- Heat Pumps
- Air Compressor
- Generators

elasto-Flex-Element isolate shock, motion and vibration of light electric motors. The horizontal stiffness is larger than the vertical stiffness. The recommended use of elasto-Flex-Elements is when the requirements are to avoid large horizontal movements.

CHARACTERISTICS AND CAPABILITIES OF ELASTO-FLEX-ELEMENTS

-Motion Isolation: Production efficiency is only possible with preventable downtime. elasto-Flex-Elements will protect sensitive electric motor or aggregates from incurred movements.

-Vibration Absorption: Most machinery transfers vibrations to the immediate environment. With the installation of our elasto-Flex-Elements the vibration transfer will be prevented.

-Noise Reduction: All Machinery not isolated produce motion and noise. An effective isolation will be evident with the installation of our elasto-Flex-Elements

ELASTO-FLEX-ELEMENTS (ADVANCED DESIGN)

The unique design of the elasto-Flex-Elements is that the horizontal stiffness is greater than the vertical stiffness, which is necessary for effective isolation issues. The ability to achieve comparatively large deflection by low loads which obtain a low natural frequency and therefore a great noise and vibration reduction.

-High Load Capacity: Different sizes for most applications. Mounts available are effective from 10 kg (22 Lbs) up to a 220 kg (500 LBS) load.



The information herein is general in nature and is not intended for specific application purposes. We suggest that product samples be tested and approved based on your intended application. We reserve the right to alter specifications or withdraw products without prior notice.

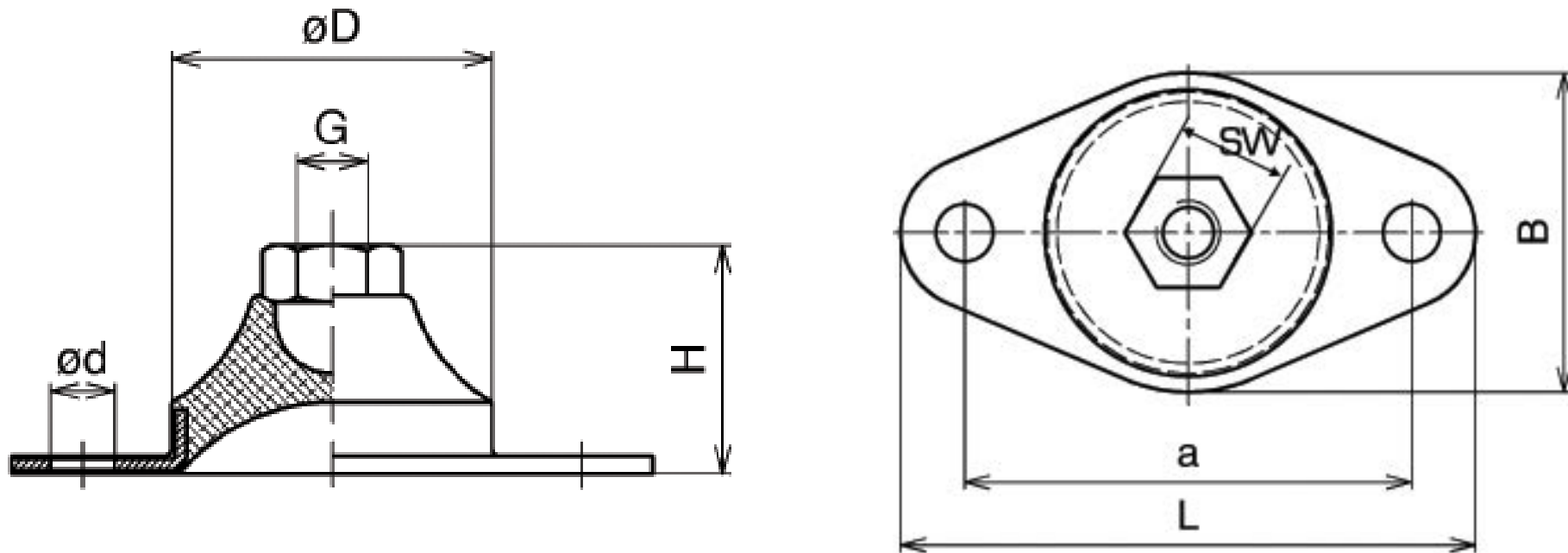

Part Number	Length x Height mm (Inch) (L) x (H)	Mounting hole (Inch) (d)	Hole Separation mm (Inch) (a)	Rubber Diameter (Inch) (D)	Flange Width (Inch) (B)	(Inch) (SW)	Thread size mm (Inch) (G)	Quality ShoreA Duro	Max. Static Shear Force (horizontal)	
									daN	lbs
H6020w	60 x 20 (2.36) x (.79)	6 (.24)	45 (1.77)	30 (1.18)	35 (1.38)	11 (.43)	M6	43	10	22
H6020								57	18	40
H6020h								68	25	56
H9032w	90 x 32 (3.54) x (1.26)	9 (.35)	70 (2.76)	45 (1.77)	50 (1.97)	17 (.67)	M10	43	22	49
H9032								57	36	81
H9032h								68	55	124
H14050w	140 x 50 (5.51) x (1.97)	13 (.51)	105 (4.13)	70 (2.76)	80 (3.15)	24 (.94)	M16	43	80	180
H14050								57	144	324
H14050h								68	220	495

UNC Threads upon request.

The information herein is general in nature and is not intended for specific application purposes. We suggest that product samples be tested and approved based on your intended application. We reserve the right to alter specifications or withdraw products without prior notice.